

Design of Reconfigurable Planar Inverted F Antenna for 5G Implementation

Dewiani¹

*Department of Electrical Engineering,
Faculty of Engineering
Universitas Hasanuddin
Gowa, South Sulawesi, Indonesia
dewiani@unhas.ac.id,*

Elyas Palantei²

*Department of Electrical Engineering,
Faculty of Engineering
Universitas Hasanuddin
Gowa, South Sulawesi, Indonesia
elyas.palantei@gmail.com*

Rayvaldo Stefan Madika³

*Department of Electrical Engineering,
Faculty of Engineering
Universitas Hasanuddin
Gowa, South Sulawesi, Indonesia
Rayvaldostefan@gmail.com*

Merna Baharuddin⁴

*Department of Electrical Engineering,
Faculty of Engineering
Universitas Hasanuddin
Gowa, South Sulawesi, Indonesia
merna.baharuddin@gmail.com*

Syafruddin Syarif⁵

*Department of Electrical Engineering,
Faculty of Engineering
Universitas Hasanuddin
Gowa, South Sulawesi, Indonesia
ssyariftuh@gmail.com*

Abstract— 5G technology is expected to be the future of wireless communication to replace its predecessors. Some countries already did some researches to find suitable frequency bands for the 5G. Frequency around 3.5GHz and 4.8GHz are considered to implement 5G. To support the technology, a suitable antenna is needed. The antenna needs to work at 5G frequency bands and need to be as small as possible to be mounted at the rear of the mobile handset. Planar inverted F Antenna is a common type of antenna for mobile handset because of its compactness and low profile. The objective of this paper is to design a planar inverted F antenna that works at 5G frequency bands. It is designed on FR4 substrate with $h = 1.6\text{mm}$ and dielectric constant $\epsilon_r = 4.3$. The patch is placed 5mm above the ground plane and connected by the shorting plate at the edge of the patch and ground plane. An extended V patch is added to get the lower frequency band. The main patch and extended patch is connected by a lumped element which represents the PIN diode which will work as a switch to achieve the reconfigurable state of the antenna. After simulated, the antenna is fabricated and measured. The results show that the antenna works fine at both 3.5GHz and 4.8GHz while radiation pattern shows a unidirectional pattern that mainly aimed at the top of the patch. The antenna design, return loss, radiation pattern, and gain are presented in this paper.

Keywords— *planar, inverted F, multiband, reconfigurable, return loss, gain, radiation pattern.*

I. INTRODUCTION

Nowadays, wireless technology keeps on evolving to fulfill the demand of telecommunication users. High data rate, flexibility, and low cost have been a demand for future wireless technology [1]. 5G technology is expected to be the future of wireless communication to replace its predecessors. With the presence of 5G in near future, the number of band services will also increase. Hence, it is needed for the mobile handset to support the frequency band and standard of 5G technology. Some countries already did some researches to find suitable frequency bands for the 5G implementation. Frequency around 3.5GHz and 4.8GHz are considered to implement 5G [2]. To support it, an antenna is required to work at the frequency band.

Planar Inverted F Antenna (PIFA) is one of the most popular antenna to be used in mobile handset because of its compactness, low profile, and can be mounted to the rear of the mobile phone [3]. It is also easy to build and fabricated and has more economical advantages. PIFA also has low electromagnetic radiation on its rear that faces the user's body so it is safer for the user [4]. There are some techniques to achieve the multiband condition, such as by adding a slot to the radiating patch of the antenna or by changing the parameters of the antenna, which is called reconfigurable antenna [5].

Reconfigurable antenna has been an interesting research topic for its application in communication, electronic surveillance, and countermeasures. It has the ability to change its frequency, bandwidth, polarization, and radiation pattern. The reconfigurable state can be achieved by using mechanic reconfiguration, material reconfiguration, or by using switch [6]. Switch is the common method to achieve a reconfigurable state. In [7], a reconfigurable multiband antenna is designed by adding slots to separate the patch into 3 parts. 2 switches are placed between the patches to control the frequency of the antenna. The same thing also happened in [8], reconfigurable printed monopole antenna is designed by cutting a part of the monopole and then connect it using a switch.

PIN diode is a switch that known widely for its application in reconfigurable antenna. Unlike normal diode, PIN diode can switch between RF frequency. It is small in size, cheaper and offers low loss operation[9], Using an external bias circuit, the state of the diode can be controlled. When a forward current run through the diode, the switch will work in ON state, otherwise when a reverse current run through the diode, it will work in OFF state.

With respect to the task of designing a reconfigurable planar inverted F antenna, several works and techniques can be found in the previous literatures. In [10] a reconfigurable PIFA antenna is designed to achieve multiband condition for wireless application by using PIN diodes and defected ground structure. A similar research has been reported in [11] but instead of PIN diode, they used varactor diode to tune the frequency band of the antenna.

The main objective of this paper is to design a reconfigurable Planar Inverted F Antenna to operate at two different frequencies. By adding a PIN diode on the patch of the PIFA, it is expected to achieve the dual band mode, which covers 5G frequencies, 3.5GHz and 4.8GHz. The antenna is expected to have return loss less than -10dB which is the standard of mobile communication antenna. All the idea is tested through simulation and measurement on an FR4 microstrip substrate of characteristics $\epsilon_r=4.3$, $h=1.6\text{mm}$ and $\tan \delta = 0.02$. The antenna will be simulated in CST Microwave Studio Suite which is commonly used for antenna and microwave simulation design. The design of the reconfigurable PIFA antenna then will be fabricated and measured. The results will be analyzed and discussed later in this paper.

II. ANTENNA DESIGN AND STRUCTURE

A. PIFA Antenna Design

PIFA antenna consists of three main elements such as top radiating patch, ground plane as reflection surface, and shorting plate. The dimension of the radiating patch is LP x WP and the dimension of the ground plane is L x W. The shorting plate with height h is used to connect the radiation patch and the ground plane. It is also used to maintain the structure of the antenna so the top patch won't collapse. Between the top patch and the ground plane, there is an air gap with dielectric constant $\epsilon_r = 1$. A feeding point is placed below the radiation patch through the ground plane. The structure of PIFA antenna is shown in fig.1.

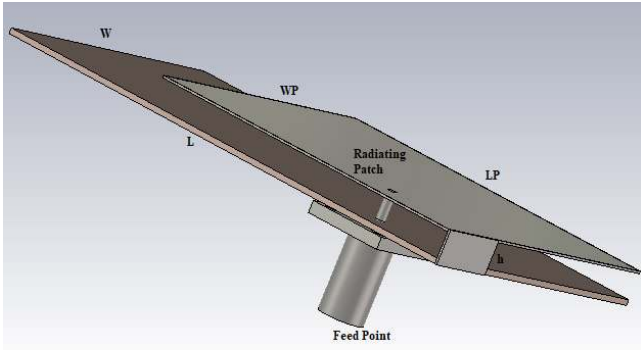

Fig. 1. Structure of PIFA Antenna

B. Equation of PIFA Antenna

Below are the equations formula of the PIFA antenna that can be used to determine the dimension of the radiating patch of the PIFA structure. The length LP and width WP are calculated based on the equation (1)

$$LP+WP=\lambda/4 \quad (1)$$

When $WS= LP$, then;

$$LP+h=\lambda/4 \quad (2)$$

When WS is close to zero $\ll Lp$, then;

$$LP+WP+h=\lambda/4 \quad (3)$$

Where $(LP + WP)$ is the total length of the patch, WS is the width of the short plate, h is the height of the patch, and λ is lambda which is the speed of light (c) divided by frequency [12].

C. Design of The Proposed Reconfigurable PIFA

The reconfigurable PIFA proposed in this paper consists of a PIFA antenna and a PIN diode on top of the patch to control the total patch size of the antenna. When the diode is in OFF condition, the diode will block the current to reach the extended patch and the antenna will work in higher frequency. Otherwise, when it is in ON condition, the diode will allow the current to reach the extended patch thus the antenna will work in lower frequency. The antenna is designed on FR4 substrate with $h = 1.6\text{mm}$ and dielectric constant $\epsilon_r = 4.3$. The patch is placed 5mm above the ground plane and connected by the shorting plate at the edge of the patch and ground plane. An extended V patch is added to get the lower frequency (3.5GHz). The main patch and extended patch are connected by a lumped element which represents the PIN diode. The antenna is fed by 50Ω SMA connector. The dimension of the antenna is shown in table 1 while figure 2 – 4 show the view of the proposed reconfigurable antenna.

Table 1. Dimension of Proposed Reconfigurable PIFA

Parameters	Dimension (mm)
Ground length (L)	65
Ground width (W)	35
Patch length (LP)	14
Patch width (WP)	9
Slot 1-4 Length	2,5
Slot 1-4 width	1
Slot 5 length	3
Slot 5 width	1
Lumped Element	1,6
Short plate width (WS)	7
Short plate height (h)	5
Extended V patch length (LV)	3
Extended V patch width (WV)	1

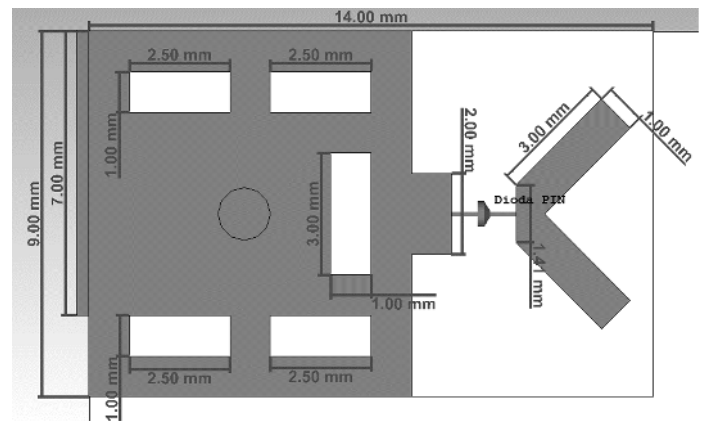

Fig. 2. Top View of Radiating Patch

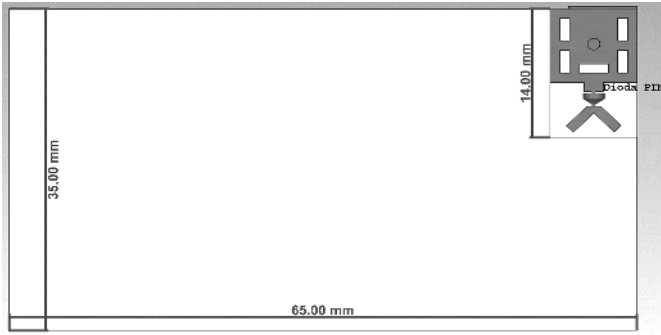

Fig. 3. Top View of Whole Structure

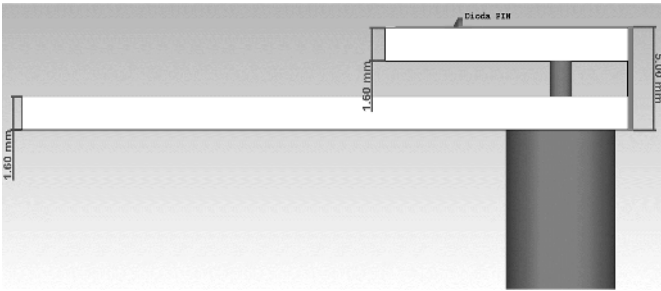

Fig. 4. Side View of Whole Structure

After passing the entire simulation, the design is fabricated for measurements. Measurements are carried out using the vector signal analyzer and anechoic chamber room to obtain return loss and radiation patterns of the antenna. The fabricated antenna is shown in figure 5. A PIN diode is placed on the top of the patch to connect the main patch of the antenna and the extended patch. An external bias circuit is created to power the PIN diode so the diode can work as the switch at both 3.5GHz and 4.8GHz.

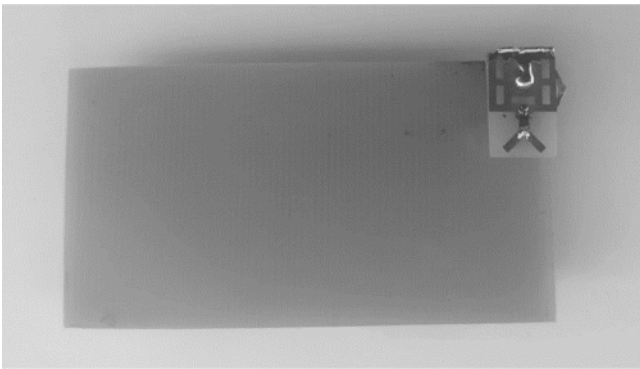

Fig. 5. Fabricated Antenna

III. RESULT AND ANALYSIS

In this section, all the results of the simulation and measurement for the reconfigurable PIFA will be explained and presented. This antenna is good enough to be used as 5G mobile handset antenna application because of the return loss value, which is lower than -10dB at both 3.5GHz and 4.8GHz. It also has wide bandwidth which is more than 1GHz for the total bandwidth.

This reconfigurable PIFA design was simulated using CST Microwave Studio. In simulation results, it is known that the ranging frequency for lower band is jumping from 3.2358GHz – 3.7985GHz, while the ranging frequency for higher band is jumping from 4.4028GHz – 5.5283GHz. After that, the measurement shows that the ranging frequency for lower band is jumping from 3.353GHz – 3.66GHz, while the

ranging frequency for high band is jumping from 4.200GHz – 4.986GHz. From the result, it can be said that the antenna satisfied both frequencies for the 5G.

A. Return Loss

Fig. 6 shows the simulated and measured return loss of the proposed antenna at both frequencies. The value of return loss at 3.5GHz resonant frequency in simulation is -39dB at 3.52GHz while in measurement it is -18.57dB at 3.49GHz. And at 4.8GHz resonant frequency, the value of return loss in simulation is -40dB at 4.867GHz, while in measurement it is -26.4dB at 4.7GHz.

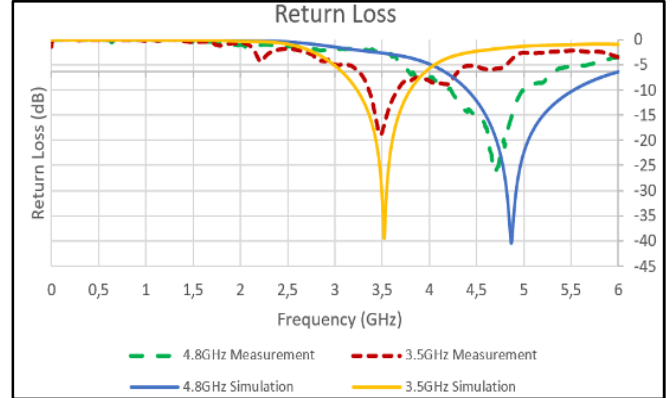

Fig. 6. Return Loss

From the graph, we can see that the resonant frequency of the fabricated antenna shifted to lower frequency. While the value is also decrease compared to simulation. Nevertheless, it is still satisfied the frequency range and return loss limit we have set before. We can also see that the bandwidth of the upper band frequency is wider than the lower band frequency which is about two times. The total bandwidth of reconfigurable multiband antenna can be calculated by using equation (4).

$$B_w = B_{wf1} + B_{wf2} + B_{wf3} + \dots + B_{wfn} \quad (4)$$

From the equation, the total bandwidth of the proposed antenna is 1.099GHz.

It has also been found that the width of the shorting plate affects the frequency, return loss, and bandwidth of the proposed antenna. Fig. 7 shows the effect of the width of the shorting plate to the simulation. From the graph, it is known that 7mm width shorting plate gives the best return loss for both lower band and upper band.

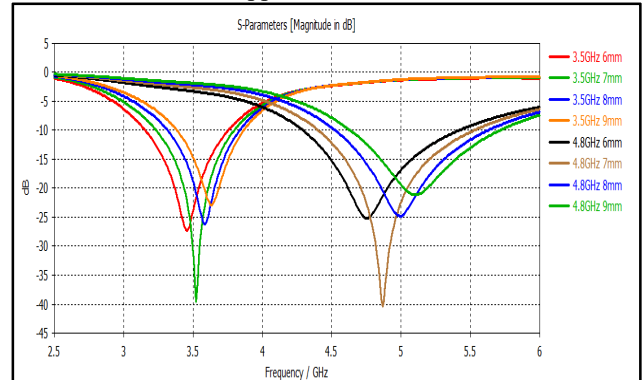

Fig.7. Effect of The Width of The Shorting Plate

B. Radiation Pattern and Gain

Fig. 8 and fig. 9 show the simulated radiation pattern of the proposed reconfigurable PIFA at both frequencies in polar

plot. It is shown in the figure that the radiation pattern for both resonant frequencies is mostly unidirectional where the main beam of the antenna is directed to the top of the patch, while the rear of the antenna which is the ground plane has low radiation. It fits the theory that PIFA antenna has low radiation at the rear make it safe for mobile communication handset.

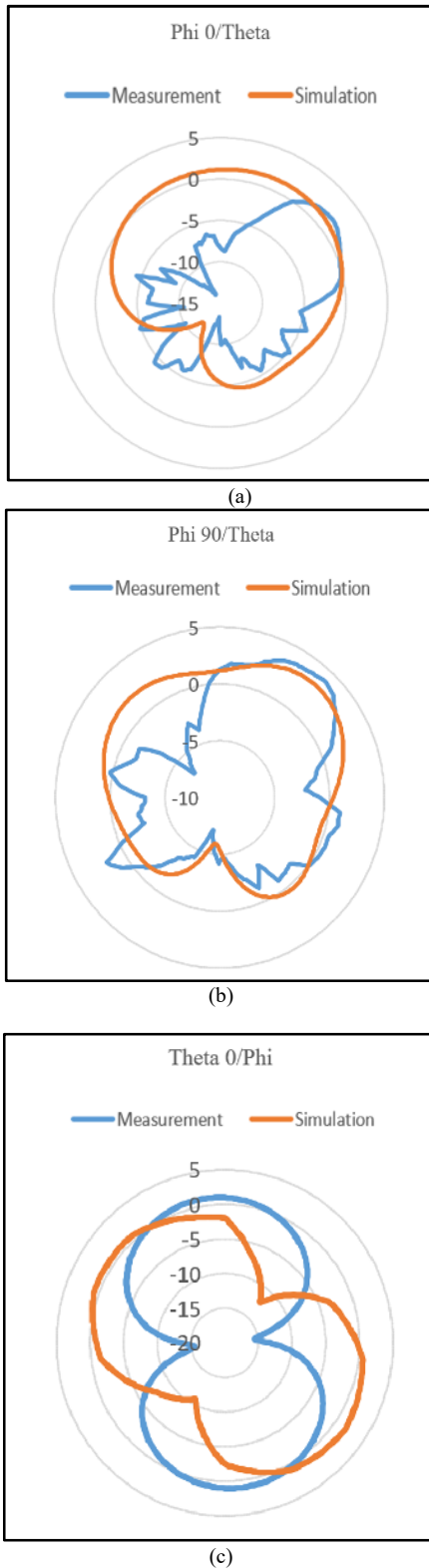

Fig. 8. Simulated & Measured Radiation Pattern at 3.5GHz Frequency (a) XZ plane (b) YZ plane (c) XY plane

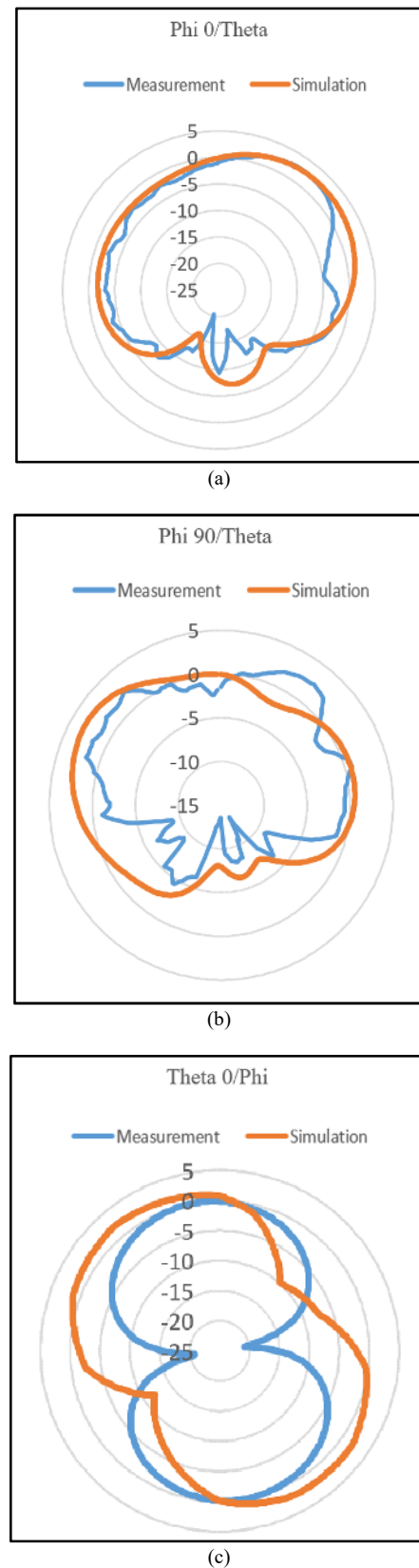

Fig. 9. Simulated & Measured Radiation Pattern at 4.8GHz Frequency (a) XZ plane (b) YZ plane (c) XY plane

From simulation and measurement, the gain of the fabricated antenna at 3.5GHz is 4.03dB compared to simulation 3.244dB. While the gain at 4.8GHz is 2.82dB compared to simulation 3.482. If we can see, the gain at 3.5GHz is bigger than the simulation. It is because the radiation pattern of the fabricated antenna at 3.5GHz is more directed than the

simulation. From fig.8a and fig.8b, we can see that there is a difference between the simulated and measured radiation pattern at 3.5GHz. Rather than having a good unidirectional pattern, it is more likely to direct into a certain direction. Compared to 4.8GHz, the radiation pattern at 3.5GHz also shows some noises that disturbing the pattern. It is the effect of the external bias circuit when antenna works at 3.5GHz. Because the diode needs to be powered by an independent power source, it interferes the measurement of the radiation pattern.

Fig. 10 and fig.11 show the simulated radiation pattern of the proposed reconfigurable PIFA at both frequencies in 3D plot. From the simulated 3D pattern, it is clearly seen that the antenna focusing its radiation at the top of the antenna, while the backside has low radiation. It is also shown that the efficiency of the antenna is around -0.5dB and 0.4dB for 3.5GHz and 4.8GHz which is mean that 94% of the power presented at the antenna input is radiated.

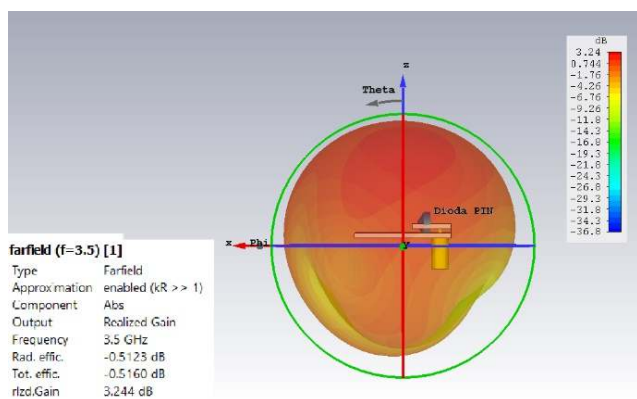

Fig. 10. Simulated Radiation Pattern in 3D at 3.5GHz

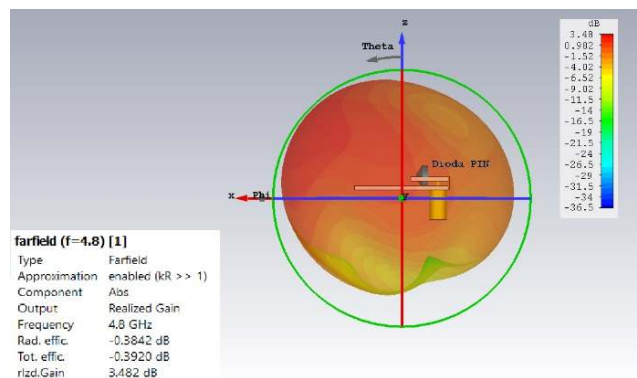

Fig. 11. Simulated Radiation Pattern in 3D at 4.8GHz

IV. CONCLUSION

In this paper, the design and construction of Reconfigurable Planar Inverted F Antenna was presented and explained. The presented antenna is used for the upcoming 5G technology that works at 3.5GHz and 4.8GHz frequency. The aim of this paper is to create an antenna that can change its parameter (reconfigurable) so the antenna can switch from low band frequency to high band frequency and vice versa. The antenna produces good return loss which is -18.57dB and -26.4dB at 3.5GHz and 4.8GHz. It also has a bandwidth which is equal to 1.099GHz. The radiation pattern of the antenna is mainly aimed at the top of the patch and has low radiation at the back of the ground plane which is suitable for mobile handset.

The research can be expanded even further by simulate the real situation of wireless communication involving two identical antennas where the receiving antenna will automatically switch to the frequency it received from the transmitting antenna. It will show the effect of the diode and the supporting system of the antenna.

ACKNOWLEDGEMENT

This work was part of the Hasanuddin University PTUH Research & Development (R&D) Project funded from DGHE (Directorate General of Higher Education), Ministry of Research, Technology and Higher Education, Republic of Indonesia. The R&D grant itself was granted for the financial year 2019. The authors would like to deliver sincere thanks to all parties who involved and supported the implementation of the research project.

REFERENCES

- [1] M. P. Deshmukh, "Evolution of wireless technology from 0G to 5G : A review," *Int. J. Comput. Sci. Inf. Technol.*, vol. 6, no. 3, pp. 2545–2551, 2015.
- [2] Huawei, "5G spectrum Public Policy Position," 2017. [Online]. Available: https://www-file.huawei.com/-/media/CORPORATE/PDF/public-policy/public_policy_position_5g_spectrum.pdf?la=en.
- [3] N. Kumar and G. Saini, "A Novel Low profile Planar Inverted-F Antenna (PIFA) for Mobile Handsets," *Int. J. Sci. Res. Publ.*, vol. 3, no. 3, pp. 3–6, 2013.
- [4] R. Bansal, A. Bisht, S. Verma, and H. S. Saini, "AN OVERVIEW ON PIFA ANTENNA DESIGN," *Int. J. Electron. Electr. Eng.*, vol. 4, no. 3, pp. 2–4, 2017.
- [5] I. F. Da Costa *et al.*, "Optically controlled reconfigurable antenna for 5G future broadband cellular communication networks," *J. Microwaves, Optoelectron. Electromagn. Appl.*, vol. 16, no. 1, pp. 208–217, 2017.
- [6] M. Rütshlin and V. Sokol, "Reconfigurable Antenna Simulation: Design of Reconfigurable Antennas with Electromagnetic Simulation," *IEEE Microw. Mag.*, vol. 14, no. 7, pp. 92–101, 2013.
- [7] V. R. Tumati and J. Cheruku, "Design and Study of Frequency Reconfigurable Antenna for Wireless Applications Venkateswara," *Int. Conf. Micro-Electronics, Electromagn. Telecommun.*, vol. 434, pp. 491–499, 2018.
- [8] A. Miguel, *Reconfigurable Antenna for Mobile Terminal*. Lisbon: Instituto Superior de Engenharia de Lisboa, 2015.
- [9] J. Kumar, B. Basu, and F. A. Talukdar, "Modeling of a PIN Diode RF Switch for Re configurable Antenna Application," *Sci. Iran.*, vol. 26, no. 3, pp. 1714–1723, 2019.
- [10] P. T. Minh, N. T. Duc, P. X. Vu, N. T. Chuyen, and V. Van Yem, "Low Profile Frequency Reconfigurable PIFA Antenna using Defected Ground Structure," *REV J. Electron. Commun.*, vol. 7, no. 1, pp. 9–17, 2017.
- [11] H. F. AbuTarboush, R. Nilavalan, and T. Peter, "PIFA based reconfigurable multiband antenna for wireless applications," *Proc. - 2010 12th Int. Conf.*

Electromagn. Adv. Appl. ICEAA'10, no. October 2010, pp. 232–235, 2010.

- [12] F. N. M. Redzwan, M. T. Ali, M. N. Md. Tan, and N. F. Miswadi, “Dual-band Planar Inverted F Antenna

with parasitic element for LTE and WiMAX mobile communication,” *ISTMET 2014 - 1st Int. Symp. Technol. Manag. Emerg. Technol. Proc.*, no. Istmet, pp. 62–67, 2014.